

CLASS 125/ CLASS 250/
PN16/PN25/JIS 10K/JIS 16K

Globe Type Silent Check Valve

Fig. 5104



Valve Standard:

Epoxy Coated, Flanged to ANSI Class 125,
BS 4504 PN16

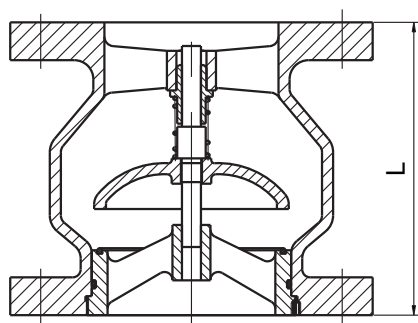

Pressure Temperature Ratings

Working pressure	16bar/25bar
Testing Pressure	Shell:24bar/37.5bar
	Seat:17.6bar/27.5bar
Working Temperature	-20°C to 110°C EPDM
	-10°C to 80°C NBR
Suitable Media	Water,Oil&Gas

Material Specification

Part	Material	ASTM Spec.	BS
Body	Cast Iron	A126 Class B	1452 Gr.220
	Ductile Iron	A536 65-45-12	1563 EN-JS1040
Disc	Ductile Iron	A536 65-45-12	1563 EN-JS1040
	Bronze	B62 C83600	1400 LG2
	SS 304	A351 CF-8	970 304S15
	SS 316	A351 CF-8M	970 316S16
Seat	Ductile Iron	A536 65-45-12	1563 EN-JS1040
	Bronze	B62 C83600	1400 LG2
	SS304	A276 S 304 00	970 304S15
Seat Ring	EPDM / NBR	Commercial	
		Bushing	Bronze
Spring	SS316	S31600	970 316S16
	SS304	S30400	970 304S15
Stem	SS 410	A276 S 410 00	970 410 S21
	SS 431	A276 S 431 00	970 431 S29
	Bronze	B62 C83600	1400 LG2

Dimensions

DN	mm	50	65	80	100	125	150	200	250	300	350	400	450	500	600
	inch	2	2-1/2	3	4	5	6	8	10	12	14	16	18	20	24
L		133	140	152	185	216	229	257	393	362	400	448	476	524	610